



# MAX7313 Evaluation Kit

## General Description

The MAX7313 evaluation kit (EV kit) is a fully assembled and tested surface-mount, 16-output LED driver circuit board. The circuit uses the MAX7313 IC, a 16-port GPIO with LED intensity control, interrupt, and hot-insertion protection. The EV kit includes four RGB LEDs and four white LEDs (WLEDs) that can be controlled simultaneously by the MAX7313. The EV kit demonstrates the MAX7313 IC's 8-bit PWM LED intensity control, 2-phase LED blinking, interrupt output, four-level I<sup>2</sup>C addressing feature.

The MAX7313 EV kit provides printed-circuit board (PCB) pads for the MAX7313 I<sup>2</sup>C serial-interface signals. A Windows 2000/XP/Vista®-compatible software is provided to access the MAX7313 IC. The MAX7313 EV kit can also be directly interfaced to a user-provided I<sup>2</sup>C system.

*Windows Vista is a registered trademark of Microsoft Corp.*

## Features

- ◆ Evaluates Four RGB and Four White LEDs
- ◆ Independent Output Control of Each LED
- ◆ Relay Driving Capable
- ◆ PC Interface or User-Supplied I<sup>2</sup>C Interface
- ◆ Windows 2000/XP/Vista (32-Bit)-Compatible Software
- ◆ USB Powered
- ◆ Surface-Mount Components
- ◆ Fully Assembled and Tested

## Ordering Information

PART	TYPE
MAX7313EVKIT+	EV Kit*

+Denotes lead-free and RoHS-compliant.

\*A high-speed A-to-B USB cable is provided with the EV kit.

# Evaluates: MAX7313

## Component List

DESIGNATION	QTY	DESCRIPTION
C1, C12, C14	3	10μF ±10%, 16V X5R ceramic capacitors (0805) Murata GRM21BR61C106K KEMET C0805C106K4PACTU
C2, C3	2	22pF ±5%, 50V C0G ceramic capacitors (0603) Murata GRM1885C1H220J TDK C1608C0G1H220J
C4	1	0.033μF ±10%, 16V X7R ceramic capacitor (0603) Murata GRM188R71C333K Taiyo Yuden EMK107BJ333KA (X5R)
C5–C10, C17, C18, C22	9	0.1μF ±10%, 16V X7R ceramic capacitors (0603) Murata GRM188R71C104K TDK C1608X7R1C104K
C11, C13	2	1μF ±10%, 16V X5R ceramic capacitors (0603) Murata GRM188R61C105K TDK C1608X5R1C105K
C15, C16	2	10pF ±5%, 50V C0G ceramic capacitors (0603) Murata GRM1885C1H100J TDK C1608C0G1H100J

DESIGNATION	QTY	DESCRIPTION
C19	1	47μF ±20%, 10V low-ESR POSCAP (C) SANYO 10TPB47MC
C20	1	1μF ±10%, 6.3V X5R ceramic capacitor (0603) Murata GRM188R60J105KA AVX 06036D105KA Taiyo Yuden JMK107BJ105KA
C21	1	4.7μF ±10%, 6.3V X5R ceramic capacitor (0805) Murata GRM21BR60J475KA AVX 08056D475KA Taiyo Yuden JMK212BJ475KG
D1–D4	4	RGB LEDs (2.8mm x 3.2mm)
D5–D8	4	White LEDs (PLCC-2)
D9	1	Green LED (0603)
FB1	0	Not installed, ferrite bead (0603)
H1	0	Not installed, 2 x 5-pin JTAG header
JU1, JU7, JU8, JU9	0	Not installed, 3-pin headers
JU2, JU3, JU4	3	5-pin headers, 0.100in centers
JU5	1	3-pin header, 0.100in centers
JU6	0	Not installed, 2-pin header

# MAX7313 Evaluation Kit

## Component List (continued)

DESIGNATION	QTY	DESCRIPTION
JU10–JU13	4	2-pin headers, 0.100in centers
P1	1	USB series B right-angle PC mount receptacle
R1, R2	2	27Ω ±5% resistors (0603)
R3, R31, R32, R33	4	1.5kΩ ±5% resistors (0603)
R4	1	470Ω ±5% resistor (0603)
R5	1	2.2kΩ ±5% resistor (0603)
R6	1	10kΩ ±5% resistor (0603)
R7	1	169kΩ ±1% resistor (0603)
R8	1	100kΩ ±1% resistor (0603)
R9–R13	0	Not installed, resistors (0402)
R14	1	220Ω ±5% resistor (0603)
R15–R18	4	56Ω ±5% resistors (0603)
R19, R22, R25, R28	4	68Ω ±5% resistors (0603)
R20, R23, R26, R29	4	120Ω ±5% resistors (0603)
R21, R24, R27, R30	4	130Ω ±5% resistors (0603)

DESIGNATION	QTY	DESCRIPTION
U1	1	16-port GPIO with LED intensity control Maxim MAX7313AEG+ (24 QSOP)
U2	1	Microcontroller Maxim MAXQ2000-RAX+ (68 QFN-EP, 10 x 10)
U3	1	LDO regulator Maxim MAX8511EXK25+ (5 SC70)
U4	1	Adjustable output LDO regulator Maxim MAX8512EXK+ (5 SC70)
U5	1	UART-to-USB converter FTDI FT232BL (32 TQFP, 7mm x 7mm)
U6	1	93C46 type 3-wire EEPROM Atmel AT93C46A-10SU-2.7 (8 SO)
Y1	1	16.000MHz crystal
Y2	1	6.000MHz crystal
—	8	Shunts
—	1	PCB: Maxim MAX7313 Evaluation Kit+

## Component Suppliers

SUPPLIER	PHONE	WEBSITE
AVX Corp.	843-946-0238	<a href="http://www.avxcorp.com">www.avxcorp.com</a>
Fairchild Semiconductor	888-522-5372	<a href="http://www.fairchildsemi.com">www.fairchildsemi.com</a>
KEMET Corp.	864-963-6300	<a href="http://www.kemet.com">www.kemet.com</a>
Murata Mfg. Co. Ltd.	770-436-1300	<a href="http://www.murata.com">www.murata.com</a>
SANYO Electric Co., Ltd.	619-661-6835	<a href="http://www.sanyodevice.com">www.sanyodevice.com</a>
Taiyo Yuden	800-348-2496	<a href="http://www.t-yuden.com">www.t-yuden.com</a>
TDK Corp.	847-803-6100	<a href="http://www.component.tdk.com">www.component.tdk.com</a>

**Note:** Indicate that you are using the MAX7313 when contacting these component suppliers.

## Quick Start

The MAX7313 EV kit is fully assembled and tested. Follow these steps to verify board operation.

### Required Equipment

- MAX7313EVKIT+ (USB cable included)
- Windows 2000/XP/Vista PC with a spare USB port

**Note:** In the following section(s), software-related items are identified by **bolding**. Text in **bold** refers to items directly from the EV kit software. Text in **bold and underline** refers to items from the Windows operating system.

## MAX7313 EV Kit Files

FILE	DESCRIPTION
INSTALL.EXE	Installs the EV kit files on your computer
MAX7313.EXE	Application program
FTD2XX.INF	USB device driver file
UNINST.INI	Uninstalls the EV kit software
USB_Driver_Help.PDF	USB driver installation help file

# MAX7313 Evaluation Kit

## Procedure

- 1) Visit [www.maxim-ic.com/evkitsoftware](http://www.maxim-ic.com/evkitsoftware) to download the most recent version of the MAX7313 EV kit software. Save the EV kit software to a temporary folder and uncompress the ZIP file, 7313Rxx.ZIP.
- 2) Install the EV kit software on your computer by running the INSTALL.EXE program inside the temporary folder. The program files are copied and icons are created in the Windows **Start | Programs** menu.
- 3) Verify that a shunt is installed on pins 1 and 3 of jumpers JU2, JU3, and JU4 (0x40 address).
- 4) Verify that shunts are installed on jumpers JU10–JU13.
- 5) Connect the USB cable from the PC to the EV kit board. A **Building Driver Database** window pops up in addition to a **New Hardware Found** message when installing the USB driver for the first time. If you do not see a window that is similar to the one described above after 30s, remove the USB cable from the board and reconnect it. Administrator privileges are required to install the USB device driver on Windows 2000/XP/Vista.
- 6) Follow the directions of the **Add New Hardware Wizard** to install the USB device driver. Choose the **Search for the best driver for your device** option. Specify the location of the device driver to be **C:\Program Files\MAX7313** (default installation directory) using the **Browse** button. During device driver installation, Windows could show a warning message indicating that the device driver Maxim uses does not contain a digital signature. This is not an error condition and it is safe to proceed with installation. Refer to the document [USB\\_Driver\\_Help.PDF](#) for additional information.
- 7) Start the EV kit software by opening its icon in the **Start | Programs** menu. The EV kit software main window should appear as shown in Figure 1.

See the *Detailed Description of Software* section for more information on the MAX7313 EV kit software operation.

## Detailed Description of Software

**Note:** Words in boldface are user-selectable features in the MAX7313 EV kit software. A mouse or the keyboard's tab key is used to navigate various items on the main window.

The MAX7313 EV kit software features four window tabs: **Global and White LED Config/Status**, **RGB LED Config/Status**, **Port Configuration**, and **Port Status**. Each tab provides various controls and labels to facilitate the evaluation of the MAX7313 EV kit. Additional controls are also provided on the software's main window and in the menu bar.

The MAX7313 EV kit software configures the I<sup>2</sup>C communication speed to 400kHz by default. The speed can be reduced to 100kHz if required, by selecting **View | 2-Wire Speed | 100kHz** from the menu bar. This configuration may be required if slower I<sup>2</sup>C devices are connected to the EV kit's SCL and SDA pads. Once the EV kit has been detected, the software continues to poll the interface, reverifying device connectivity. To disable device polling, deselect the **Options | Poll U1** menu item.

The main window's status bar provides connection and communication information. The left section of the status bar provides the current connection status between the PC and EV kit. The right section of the status bar provides communication status in regards to sending and receiving data to and from the MAX7313 IC.

The software has a demo mode that is accessible by selecting the **Options | Demo Mode** menu item. When in demo mode, all software communication with the EV kit hardware is disabled. This feature enables a user to evaluate the software without hardware connectivity.

## Software Startup

Upon starting the program, the MAX7313 EV kit software establishes a connection with the EV kit's on-board interface and automatically detects the U1 serial address. Once a connection has been made, the software initializes the MAX7313 IC and starts up with the **Global and White LED Config/Status** tab selected (see Figure 1). When initialized, the IC is configured to operate with ports P0–P15 as outputs and port INT/O16 as an interrupt output. Table 1 lists the initialized state of the device registers.

# MAX7313 Evaluation Kit

Evaluates: MAX7313

**Table 1. Initial Configuration**

REGISTER	INITIALIZE CONDITION	REGISTER DATA
Blink Phase 0 Outputs P7–P0	Outputs low	0x00
Blink Phase 0 Outputs P15–P8	Outputs low	0x00
Ports Configuration P7–P0	Outputs	0x00
Ports Configuration P15–P8	Outputs	0x00
Blink Phase 1 Outputs P7–P0	High-impedance outputs	0xFF
Blink Phase 1 Outputs P15–P8	High-impedance outputs	0xFF
Master, O16 intensity	PWM oscillator is enabled; master intensity is 1/15; O16 intensity is 8/16*	0x17
Configuration	$\overline{\text{INT}}$ /O16 is interrupt output; blink is disabled; global intensity is enabled	0x0C
Outputs intensity P1, P0 . . . Outputs intensity P15, P14	PWM outputs (intensity duty cycle is 8/16)	0x77

\*See the *Global Configuration/Status* section.

### Software Reset

The MAX7313 can be returned to its power-on-reset (POR) state by selecting **File I Reset** from the menu bar. After a reset has been performed, ports P0–P11 are configured as inputs. This is reflected on the software’s **Port Configuration** and **Port Status** tabs. Although the P0–P11 ports are configured as inputs on reset, the EV kit is designed to operate with P0–P11 as output-only ports. Pressing the **Configure** button on the **Port Configuration** tab configures the P0–P11 ports as outputs. Refer to the MAX7313 IC data sheet for details on the device’s power-up configuration.

### Global and White LED Config/Status

The **Global and White LED Config/Status** tab contains two group boxes. The **Global Configuration/ Status** group box is used to enable/disable various MAX7313 global functions. The **White LED/Flash Configuration** group box is used to configure the WLED output ports, as well as provide flash capability. See the *Global Configuration/Status* and *White LED/Flash Configuration* sections for details on each group box’s controls.

#### Global Configuration/Status

The **Global Configuration/Status** group box provides controls to configure global device settings: blink enable, blink, and LED intensity control. The **Static Outputs** and **Global Intensity Control** checkboxes are used to set the desired LED intensity control scheme. The **Master Intensity** and **Global Intensity** track bars are used to configure the desired LED intensity. See Table 2 for details on configuring the device for one of

the three intensity control schemes. When configured for static and PWM outputs, see the *White LED/Flash Configuration* and *RGB LED Config/Status* sections for more details. Refer to the MAX7313 IC data sheet for additional LED intensity control details.

#### White LED/Flash Configuration

The **White LED/Flash Configuration** section is used to turn the EV kit’s WLEDs (D5–D8) on and off, adjust WLED intensity, and provide control of all four WLEDs as a single flash unit. The **Phase 0** and **Phase 1** checkboxes are used to set or clear the respective bit in that blink phase register. When checked, the associated output port is set low, turning the respective WLED on. When unchecked, the associated output port is high impedance. The **WLED Intensity** track bar independently controls the intensity of all WLEDs (D5–D8). Refer to the MAX7313 IC data sheet for additional intensity setting details.

Flash features such as **Single Flash**, **Repeat Flash**, and time delays from **0.5s to 8s** duration can be selected. To utilize the flash feature, the **Enable Flash Timer** checkbox must be checked. Pressing the **Run Flash** button initiates the flash sequence. The **Single Flash**, **Repeat Flash**, and flash timer settings can be changed on the fly. When running the flash, all global **BLINK** checkboxes are unchecked and all white LED checkboxes are disabled. To stop the flash sequence press the **Stop Flash** button, and to disable the flash feature, uncheck the **Enable Flash Timer** checkbox.

**Warning: Do not continuously stare at LEDs.**

# MAX7313 Evaluation Kit

Evaluates: MAX7313

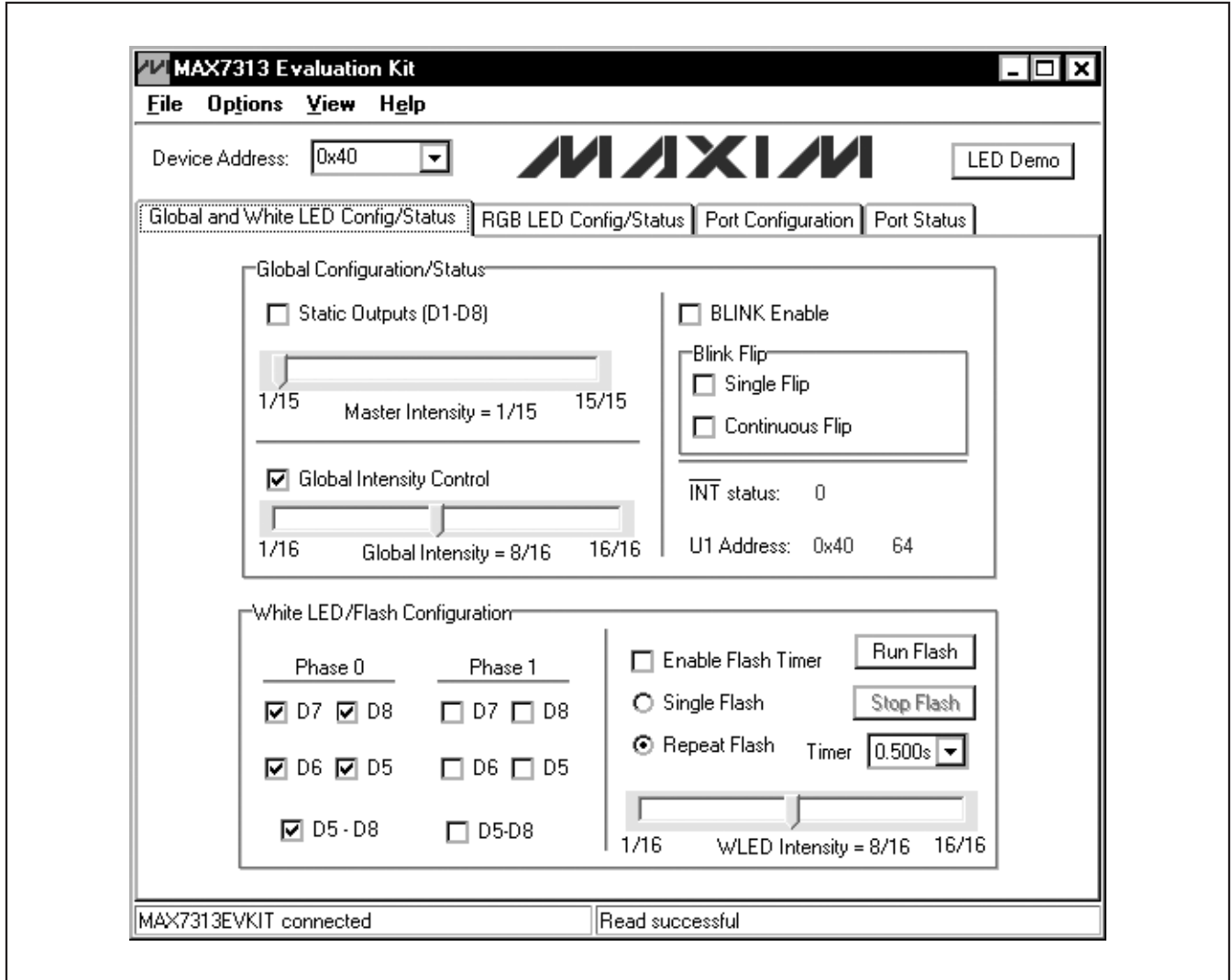

Figure 1. MAX7313 Evaluation Software Main Window (Global and White LED Config/Status Tab)

**Table 2. Intensity Control Scheme**

CONFIGURATION	STATIC OUTPUTS CHECKBOX	MASTER INTENSITY TRACK BAR	GLOBAL INTENSITY CONTROL CHECKBOX	GLOBAL INTENSITY TRACK BAR
Static Outputs	<input checked="" type="checkbox"/>	Disabled. Set at 0/15.	X	X
PWM Outputs	<input type="checkbox"/>	Enabled. Set from 1/15 to 15/15.	<input checked="" type="checkbox"/>	Enabled. Set from 1/16 to 16/16.
Static and PWM Outputs	<input type="checkbox"/>	Enabled. Set from 1/15 to 15/15.	<input type="checkbox"/>	Disabled.

\*See the Global Configuration/Status section.

## MAX7313 Evaluation Kit

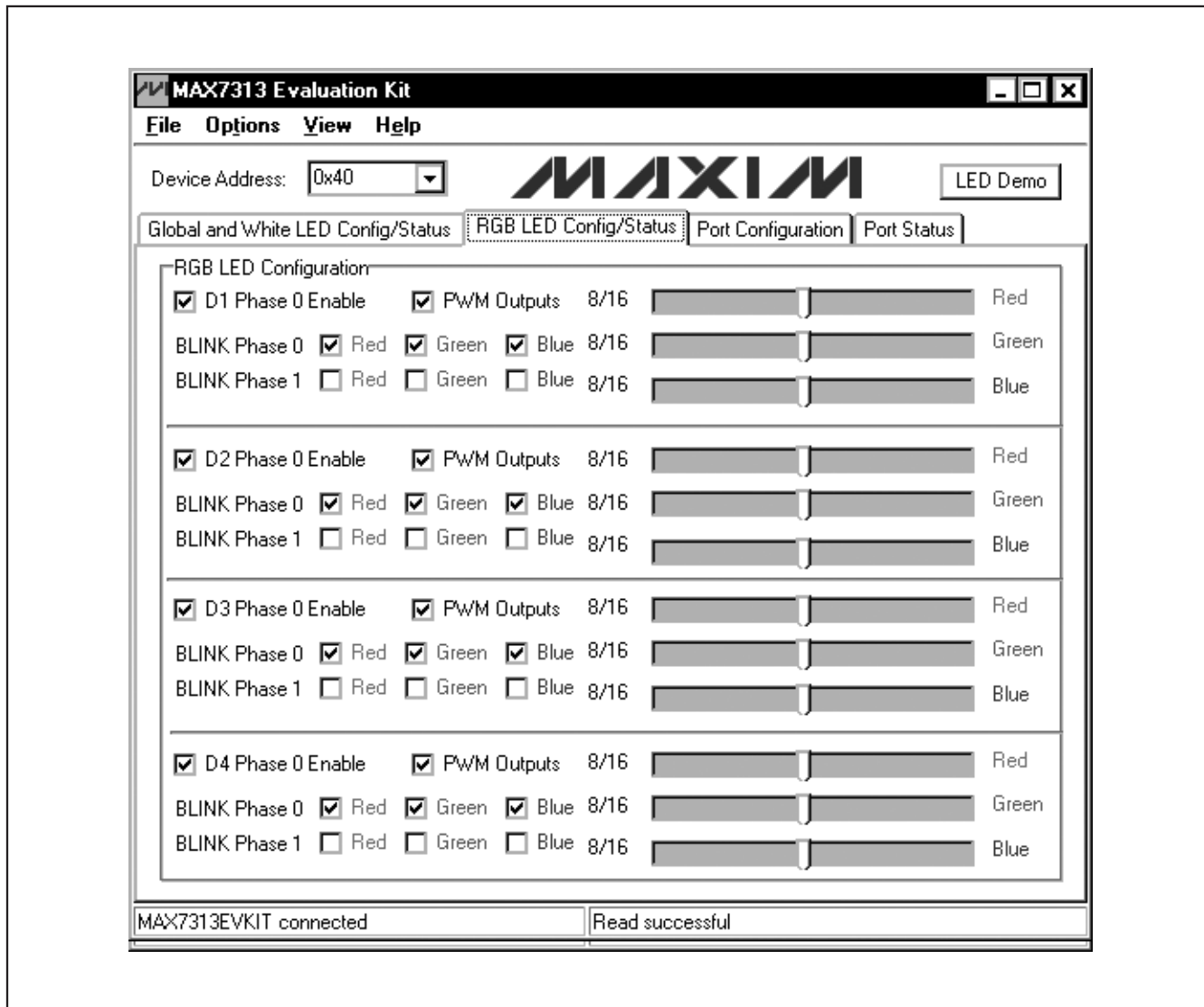

Figure 2. MAX7313 Evaluation Software RGB LED Config/Status Tab for Configuring the RGB LEDs, D1–D4

### RGB LED Config/Status

The **RGB LED Config/Status** window (see Figure 2) provides full control of the EV kit's RGB LEDs, D1–D4. Select the respective **D\_ Phase 0 Enable** checkbox to enable or disable the respective RGB LED. Select the phase 0 **Red**, **Green**, or **Blue** checkboxes to enable the respective LED color during phase 0. When **Enable PWM** is selected, the RGB LED's track bar independently controls the respective LED's color intensity.

When disabled, the track bars are set to full scale, reflecting the state of the MAX7313 IC intensity register.

Select the phase 1 **Red**, **Green**, or **Blue** checkboxes to enable the respective LED during phase 1. Phase 1 settings are used to demonstrate blink mode operation. The global **BLINK Enable** must be selected on the **Global and White LED Config/Status** tab window for the blink function to work.

# MAX7313 Evaluation Kit

Evaluates: MAX7313

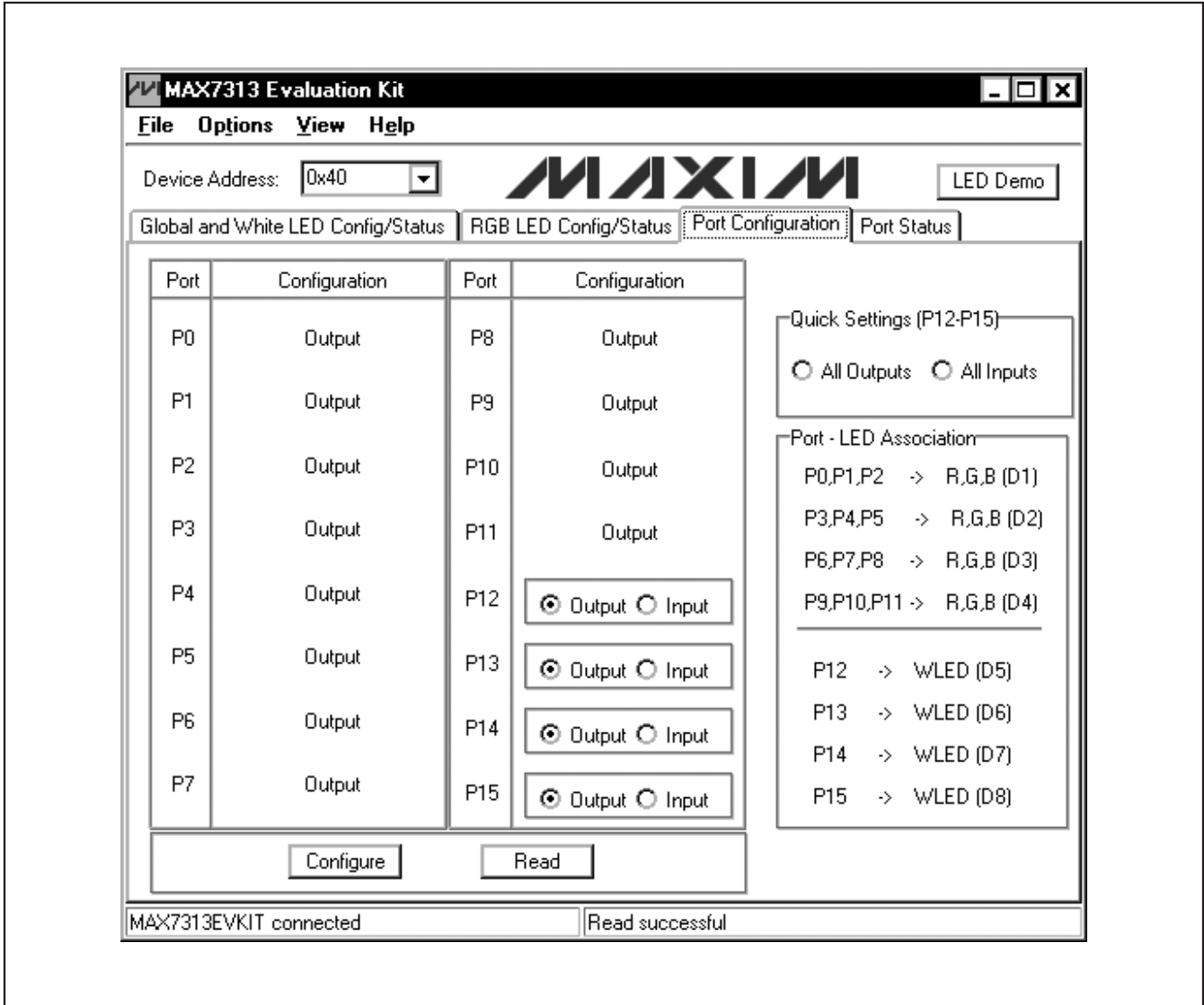

Figure 3. MAX7313 Evaluation Software Main Window (Port Configuration Tab)

### Port Configuration

As configured, the EV kit allows for the evaluation of the P12–P15 GPIO ports as inputs or outputs by selecting the port’s **Output** or **Input** radio button. The P0–P11 ports are hardware configured for output-only operation. See the *Software Reset* section for details on the state of the P0–P11 ports after a reset condition.

The **Quick Settings** group box provides two settings that, when selected, automatically configure the

P12–P15 ports as all outputs or all inputs. When making individual changes to the P12–P15 port’s configuration, the **Configure** button must be pressed for the setting to take affect. For reference, a group box containing port and LED labels is provided, listing the associations between the P0–P15 ports and the on-board LEDs.

# MAX7313 Evaluation Kit

## Port Status

The state of the P0–P15 ports can be monitored on the **Port Status** tab. By pressing the **Refresh** button, the State labels are updated to reflect the current status of each port. When configured as an output, the port’s associated label shows Output. When configured as an

input, the port’s associated label shows a 1 if the port is pulled high or a 0 if the port is pulled low. To have the **Port Status** tab automatically refreshed, check the **Polling Enabled** checkbox.

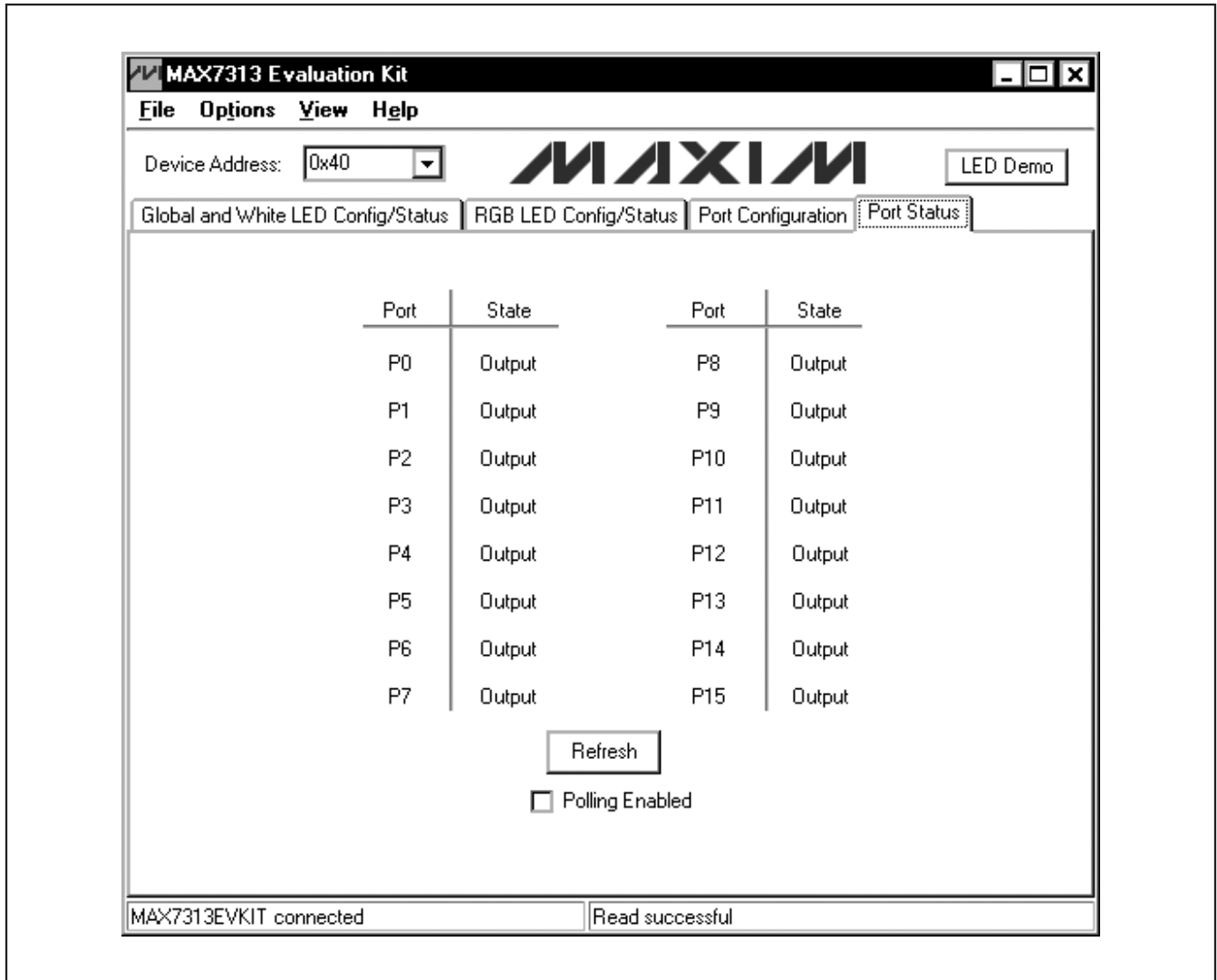

Figure 4. MAX7313 Evaluation Software Main Window (Port Status Tab)



# MAX7313 Evaluation Kit

Evaluates: MAX7313

## Register View

The contents of the Port Configuration Registers; Output Intensity Registers; Blink Phase Registers; Master, O16; and Configuration registers can be monitored by opening the **Register View** window, which is accessible by selecting the **View | Register View** menu item. Refer to the MAX7313 IC data sheet for additional register information.

## LED Demo

The **LED Demo** button provided on the software's main window provides a demonstration of the EV kit's operation. Pressing the **LED Demo** button results in the WLEDs and RGBs performing a sequence of blinks, demonstrating the LED control capabilities of the MAX7313 device.

## General-Purpose 2-Wire Interface Utility

The general-purpose **2-wire interface** utility can also be used to communicate with the MAX7313. Use the **View | Interface** menu item to access the utility. The utility configures the 2-wire serial interface parameters, such as start and stop bits, acknowledgements, and clock timing. The 2-wire interface screen allows general-purpose 2-wire commands to be sent using the **SMBusWriteByte** and **SMBusReadByte** options. The interface utility only accepts and outputs hexadecimal number format.

The **Hunt for active listeners** button scans the entire 2-wire address space, reporting each address that is acknowledged. The **SMBusWriteByte** transmits the device address, command, and one byte of data. The **SMBusReadByte** transmits the device address, a command, and then retransmits the device address and reads one byte of data.

For information on the differences between an I<sup>2</sup>C and a SMBus™ interface, read Application Note 476 *Comparing the I<sup>2</sup>C Bus to the SMBus* at [www.maxim-ic.com/appnotes.cfm/an\\_pk/476](http://www.maxim-ic.com/appnotes.cfm/an_pk/476).

*SMBus is a trademark of Intel Corp.*

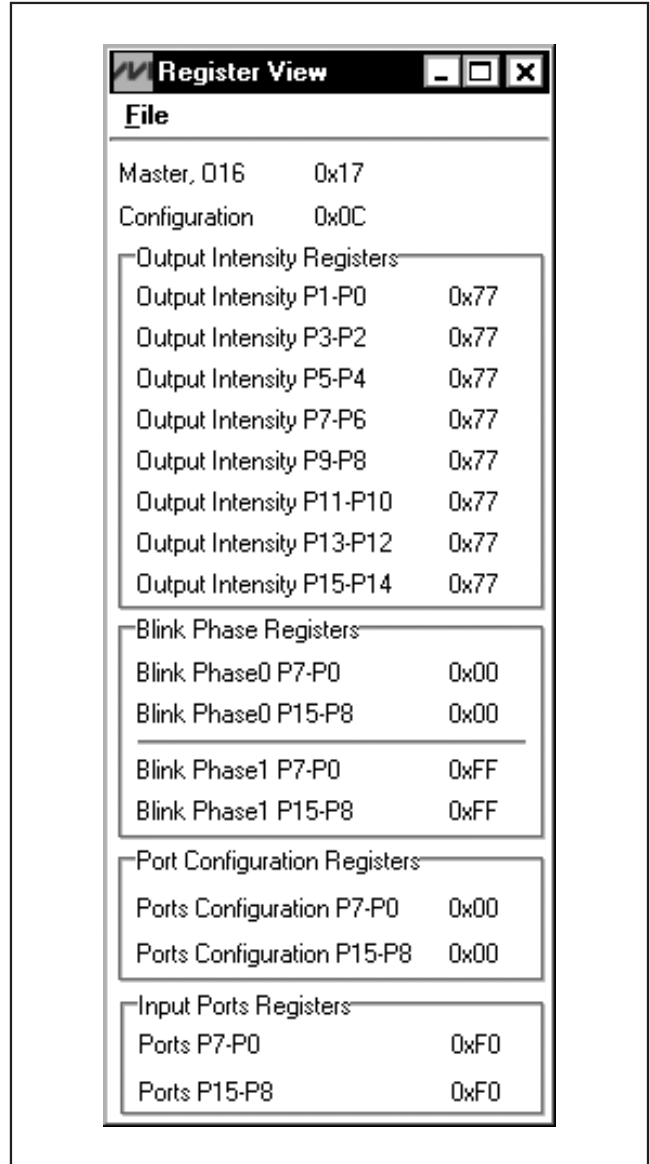

Figure 5. MAX7313 Evaluation Software Register View Window

# MAX7313 Evaluation Kit

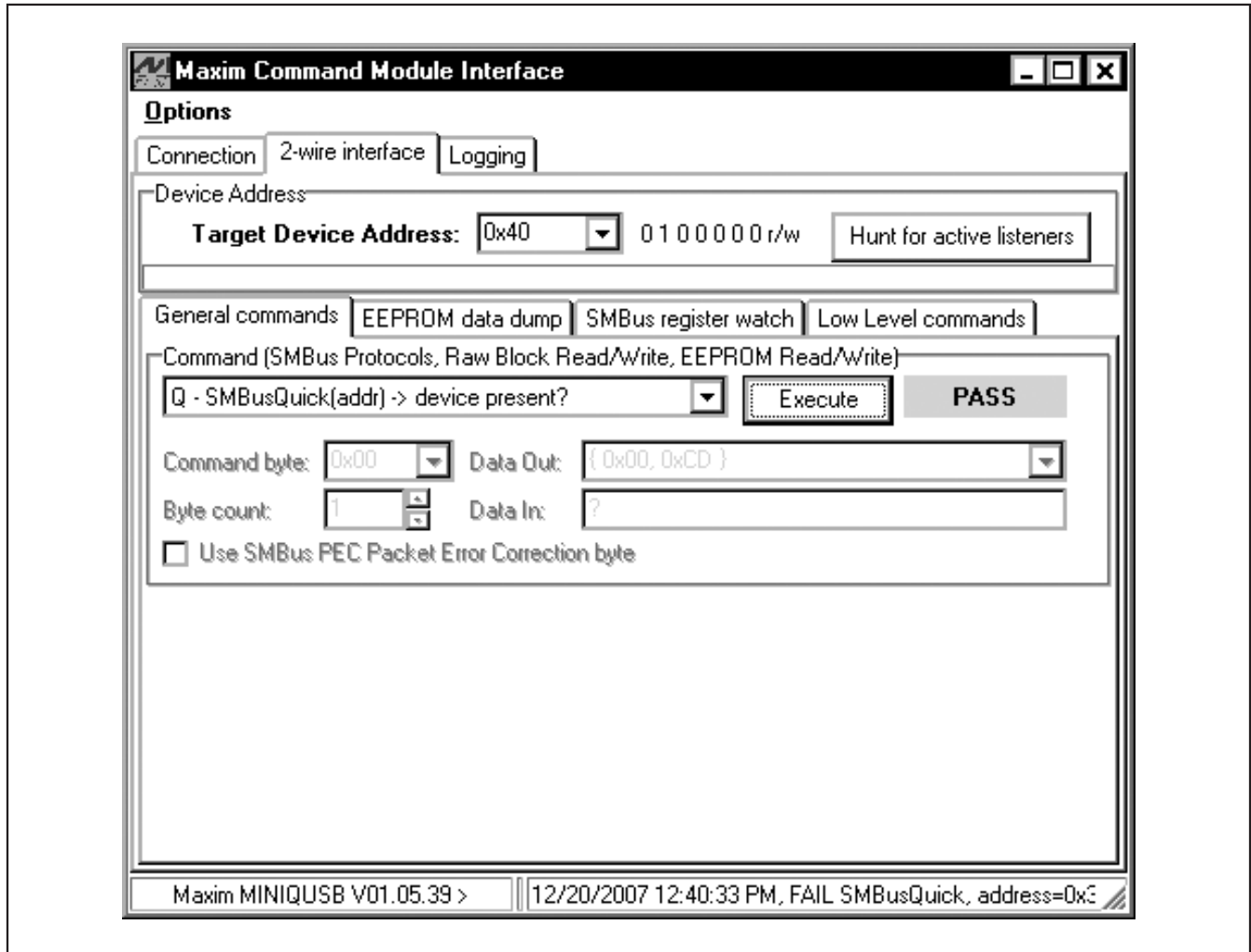

Figure 6. 2-Wire Interface Window Provides Direct, Low-Level Access to the MAX7313 and 2-Wire Serial Interface

## General Troubleshooting

### Problem: Software reports it cannot find the on-board interface.

- Is the power indicator LED (D9) on?
- Is the USB communications cable connected?
- Has Windows plug-and-play detected the board? Bring up **Control Panel>System>Device Manager**, and look at what device nodes are indicated for USB. If there is an unknown device node attached to the USB, delete it. This process forces plug-and-play to try again.

### Problem: Unable to find U1.

- Is power applied to the MAX7313 EV kit V+ PC pad or is jumper JU1 configured to pins 2 and 3 to receive power from the USB interface? This is required for powering U1.
- If using the EV kit's on-board interface, are the SCL and SDA signals pulled up to +3.3V? If using a user-supplied interface, are the SCL and SDA signals pulled up to the appropriate voltage level. There must be pullup resistors for the I<sup>2</sup>C SCL and SDA signals.
- If using jumper wires to connect, are the SCL and SDA signals swapped? Is the ground return missing?

# MAX7313 Evaluation Kit

Evaluates: MAX7313

## Detailed Description of Hardware

The MAX7313 EV kit demonstrates the MAX7313 16-port GPIO with LED intensity control. The EV kit utilizes the device's 16 GPIO ports to drive four RGB LEDs and four WLEDs. The device's output-only pin ( $\overline{\text{INT}}/\text{O16}$ ) is used as an interrupt output. In addition, the EV kit provides a relay interface (JU6) and the ability to evaluate four of the 16 GPIO ports as inputs (P12–P15). The LEDs can be controlled independently and their intensity varied using the appropriate MAX7313 8-bit PWM control register. The device's 2-phase LED blink-control feature and 3-pin, 1-of-64 I<sup>2</sup>C address feature can also be evaluated. The device requires 3.3V for operation and is powered by the EV kit circuit's V+ rail.

The MAX7313 EV kit provides SCL and SDA PCB pads for the I<sup>2</sup>C serial-interface signals. These pads can be connected directly to a user-provided I<sup>2</sup>C system that has pullup resistors for the SCL and SDA signals. Jumpers JU2, JU3, and JU4 are used to configure the MAX7313 IC's I<sup>2</sup>C address. A PCB pad is also provided for the MAX7313 AD0, AD1, and AD2 pins. See Table 4 for additional information.

### EV Kit Circuit V+ Source

The MAX7313 EV kit provides jumper JU1 to select the source for the V+ rail of the EV kit circuit. By default, the V+ rail is set to 3.3V, which is supplied by the interface circuit. Alternatively, the EV kit's VDD pad can be used to supply 3.3V to the circuit's V+ rail. The interface circuit is powered through a PC's USB port. Table 3 lists the various jumper options for powering the circuit's V+ rail.

**Table 3. JU1 Configuration**

SHUNT LOCATION	MAX7313 V+ PIN	EV KIT 3.3V SUPPLY SOURCE
1-2*	Connected to 3.3V	Interface circuit
2-3	Connected to the VDD pad (cut the trace between pins 1-2 before shorting pins 2-3)	External supply

\*Default position.

### MAX7313 I<sup>2</sup>C Serial-Interface Address

The MAX7313 EV kit provides jumpers JU2, JU3, and JU4 for configuring the I<sup>2</sup>C serial-interface address of the MAX7313. The three address pins allow for 64 possible slave addresses. Refer to the *Slave Address* section and Table 3 in the MAX7313 IC data sheet for all possible address configurations. Table 4 lists the configuration options for jumpers JU2, JU3, and JU4.

**Table 4. JU2, JU3, and JU4 Configuration**

SHUNT LOCATION	MAX7313 AD_ PIN
1-2	Connected to V+
1-3*	Connected to GND
1-4	Connected to SCL
1-5	Connected to SDA
Not installed	Connected to AD_ pad

\*Default position.

### I<sup>2</sup>C Interface

The EV kit allows for evaluating the MAX7313 with the on-board I<sup>2</sup>C interface or a user-supplied I<sup>2</sup>C interface. This is accomplished by configuring jumpers JU1, JU8, JU9, and JU10, accordingly.

On-board interface:

- 1) Configure jumpers JU7 ( $\overline{\text{INT}}$ ), JU8 (SCL), and JU9 (SDA) according to Table 5.
- 2) Configure jumper JU1 with a shunt on pins 1-2 (see Table 3).

User-supplied interface:

- 1) Configure jumpers JU7 ( $\overline{\text{INT}}$ ), JU8 (SCL), and JU9 (SDA) according to Table 5.
- 2) Cut the trace between pins 1-2 of jumper JU1 and place a shunt on pins 2-3 of JU1.
- 3) Connect the  $\overline{\text{INT}}$  pad to an interrupt handling pin on the user-supplied interface.
- 4) Connect the SDA and SCL lines from the user-supplied interface to the SDA and SCL pads.
- 5) Connect the I/O supply voltage of the user-supplied interface across the VDD and GND pads.

When evaluating the EV kit with a user-supplied interface, ensure that the SCL, SDA, and  $\overline{\text{INT}}$  lines are pulled up to the I/O supply voltage through appropriate pullup resistors. When using the on-board I<sup>2</sup>C interface, 1.5k $\Omega$  pullup resistors (R31, R32, R33) are provided on each of the SCL, SDA, and  $\overline{\text{INT}}$  lines.

# MAX7313 Evaluation Kit

Table 5. JU7, JU8, and JU9 Configuration

JU7 SHUNT LOCATION (INT)	JU8 SHUNT LOCATION (SCL)	JU9 SHUNT LOCATION (SDA)	I <sup>2</sup> C INTERFACE
1-2*	1-2*	1-2*	On-board
2-3	2-3	2-3	User-supplied (cut the trace between pins 1-2 of JU7, JU8, JU9 before shorting pins 2-3 of JU7, JU8, JU9)

\*Default position.

### LED Supply

The EV kit provides two options for powering the on-board LEDs. Jumper JU5 connects the LEDs to the 5V (typ) supply from the PC's USB port or to an external supply voltage connected to the VLED pad. When evaluating the EV kit with a user-supplied I<sup>2</sup>C interface, an external supply must be used to power the on-board LEDs. Table 6 lists the LED supply voltage options.

Table 6. JU5 Configuration

SHUNT LOCATION	LED SUPPLY VOLTAGE
1-2*	PC's USB port
2-3	External supply (cut the trace between pins 1-2 before shorting pins 2-3)

\*Default position.

### Evaluating Device Inputs

The EV kit provides jumpers JU10–JU13 to allow for the use of the P12–P15 pins as input ports. The P0–P11 pins can be configured as inputs, but are only utilized as outputs on the MAX7313 EV kit. To utilize the P12–P15 pins as inputs, remove the shunts from JU10–JU13 and connect the input signal to the left-most pin of the jumper.

### Relay Evaluation

The EV kit circuit can also be reconfigured for evaluating a 5V-rated relay by using jumper JU6. Remove the shunt from jumper JU10 and connect the relay across jumper JU6. The MAX7313 can sink up to 50mA on the output.

# MAX7313 Evaluation Kit

Evaluates: **MAX7313**

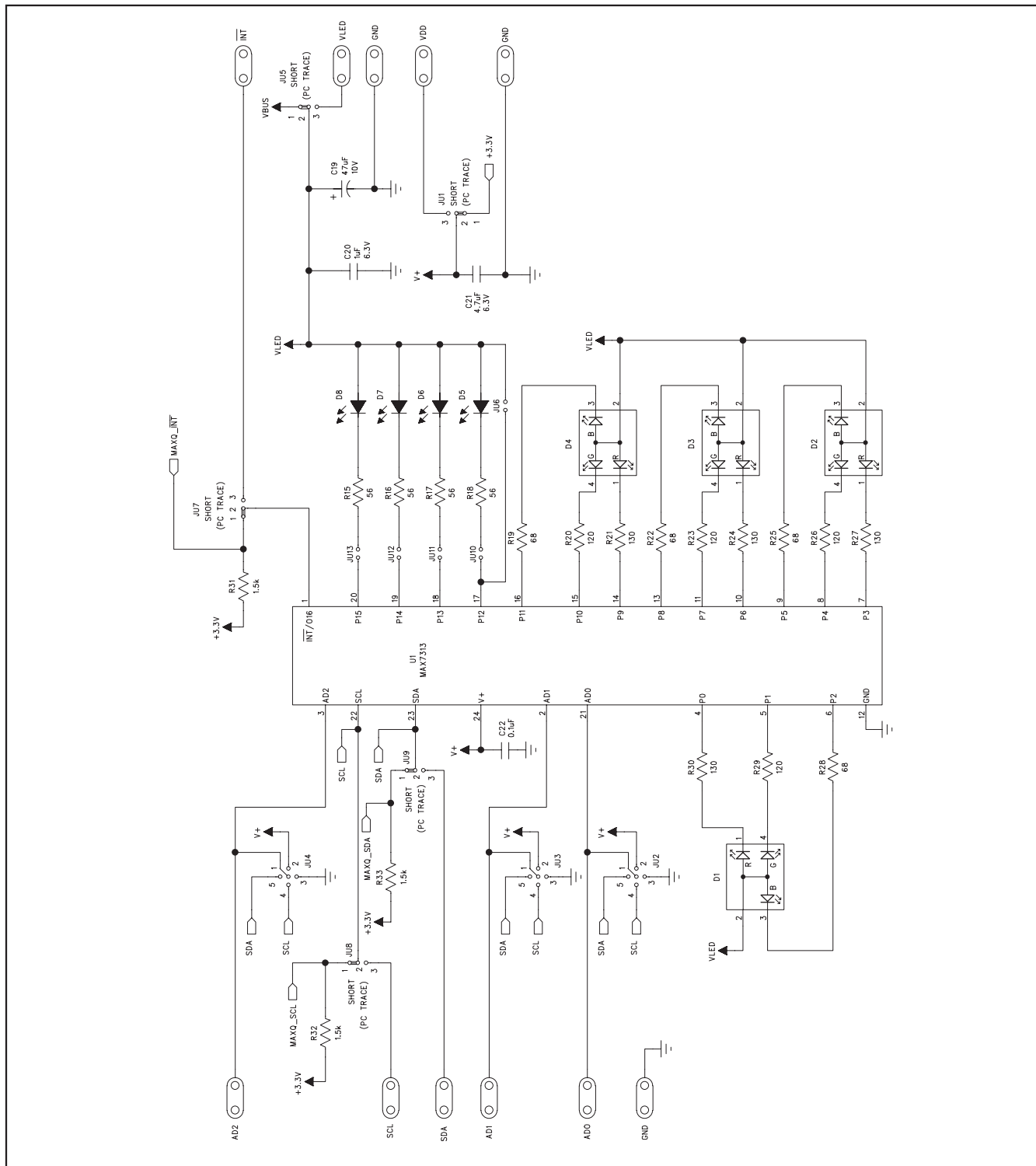

Figure 7a. MAX7313 EV Kit Schematic (Sheet 1 of 2)



# MAX7313 Evaluation Kit

Evaluates: MAX7313

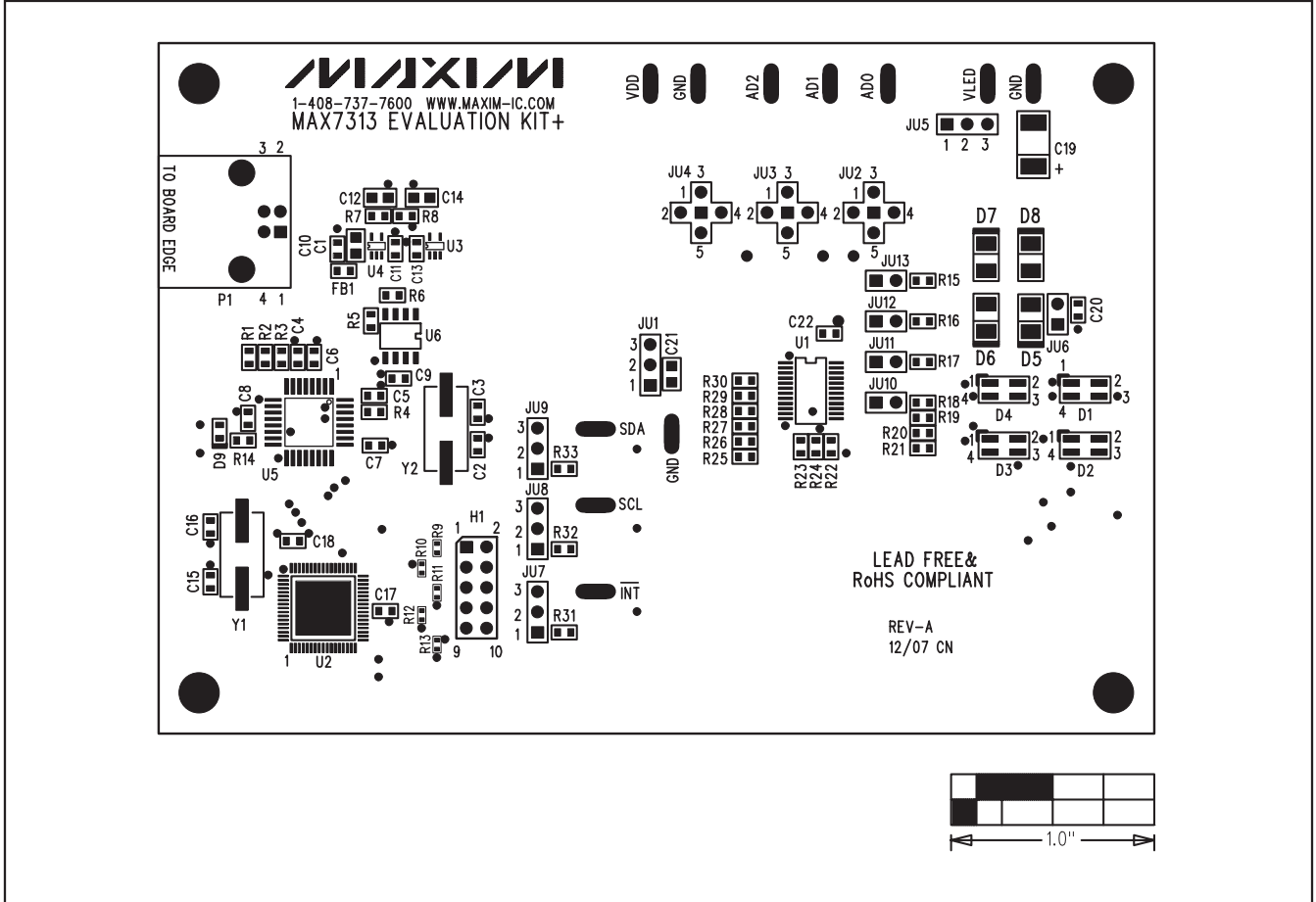

Figure 8. MAX7313 EV Kit Component Placement Guide—Component Side

# MAX7313 Evaluation Kit

Evaluates: MAX7313

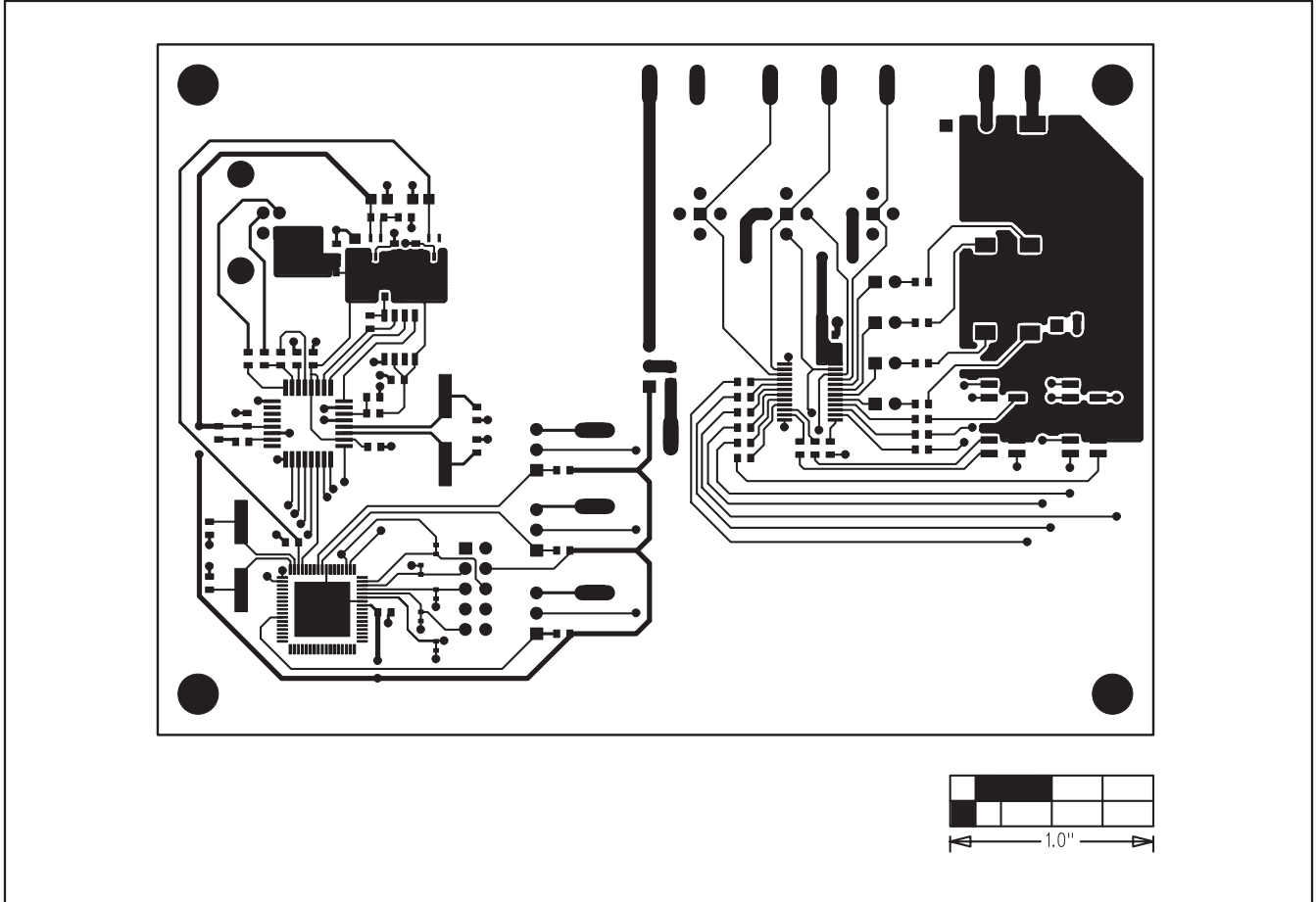

Figure 9. MAX7313 EV Kit PCB Layout—Component Side



# MAX7313 Evaluation Kit

Evaluates: **MAX7313**

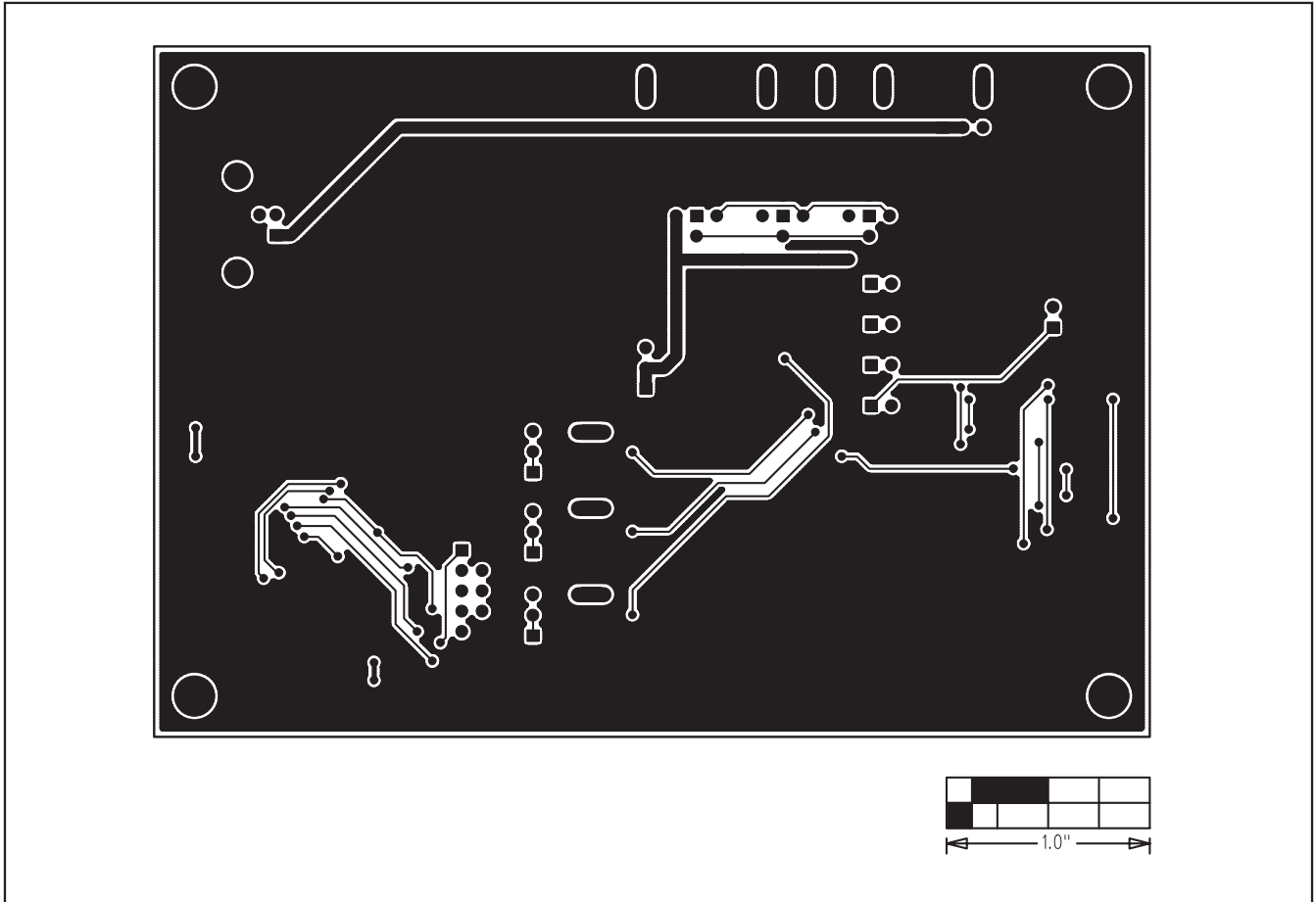

Figure 10. MAX7313 EV Kit PCB Layout—Solder Side

Maxim cannot assume responsibility for use of any circuitry other than circuitry entirely embodied in a Maxim product. No circuit patent licenses are implied. Maxim reserves the right to change the circuitry and specifications without notice at any time.

**Maxim Integrated Products, 120 San Gabriel Drive, Sunnyvale, CA 94086 408-737-7600** \_\_\_\_\_ 17